

1. Scope :

This specification applied to the products of Lead-Free current sensing resistor of metal foil for Lead-Free CRLP series manufactured for Cal-Chip Electronics, INC.

2. Type Designation :

<u>CRLP</u> Item	<u>25</u> Series No	<u>F</u> Resistance tolerance	<u>E</u> Packaging	<u>E</u> Power Rating	<u>R010</u> Resistance
	25:2512 (6432)	F:±1% G:±2% J:±5%	E: Embossed Tape	C=1W E=2W G=3W	e.g : R010=10mΩ

3. Construction and Dimension :

3.1 Construction:

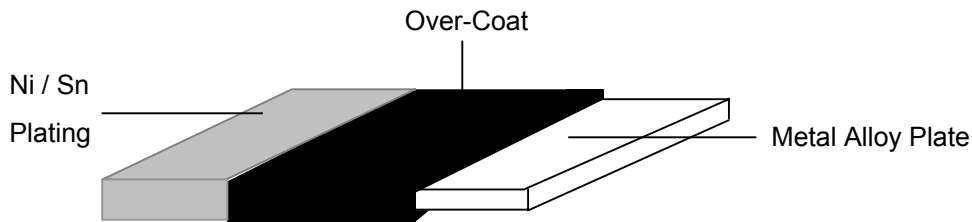

3.2 Dimension:

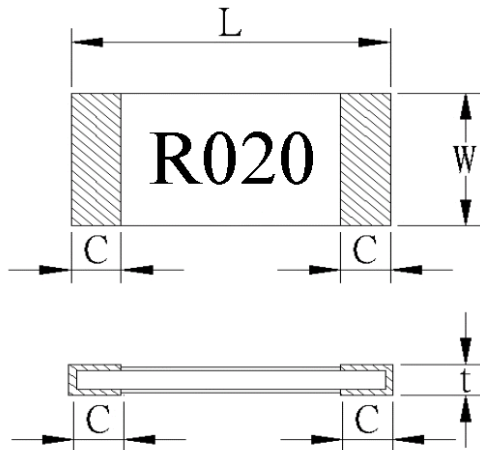

Unit : mm

Style	L	W	C	t	Material
RLP25	6.4±0.2	3.2±0.2	0.9±0.2	0.7 ±0.20	Metal : Copper-Nickel Alloy or Copper-manganese Alloy Over Coating : molding Compound UL-94 grade

	Lead-Free High Power Current Sensing Resistors CRLP Series	Document No	CRLP-250S001B
		Issued date	2008/3/8
		page	2/6

4. Features:

Type	CRLP
Power Rating	1W、2W、3W
Resistance Value	10~100mΩ
Operation Temperature Range	-55℃~+170℃
Temperature Coefficient of Resistance	75ppm/℃
Tolerance	±1%,±2%,±5%
Insulation Resistance	Over 100MΩ
Maximum Working Voltage(V)	$(P \cdot R)^{1/2}$

5. Reliability Tests :

Test Items	Condition of Test	Test Limits
Temperature Coefficient of Resistance	+25℃ ~ +125℃	Refer 4.0
Load Life	1000hours at rated power, 70℃, 1.5hours "ON", 0.5hour "OFF"	±1%
Short Time Overload	5 X rated power for 5s	±0.5% (For 40-100 mΩ rated power x 2.5 for 5 s)
Moisture no Load	85℃, 85%RH, 1000hrs	±0.5%
Temperature cycle	-40℃ & +125℃, 1000cycle, 15min per extreme condition	±0.5%
Resistance to Soldering Heat	260±5℃ for 20±1 sec	±0.5%
Solderability	245±5℃, 2±0.5sec	At least 95% of surface area of electrode shall be covered with new solder
High Temperature Exposure	170℃, 1000hrs	±0.5%
Low Temperature Storage	-55℃, 1000hrs	±0.5%
Substrate Bending	Bending width 2mm, Epoxy thickness 1.6mm, Fulcrums distance 90mm	±1.0%
Insulation Resistance	100V DC for 1 minute	>100 MΩ

Note: 2&3watts total Solder pad and trace size of 300mm²

5.1 Derating Curve

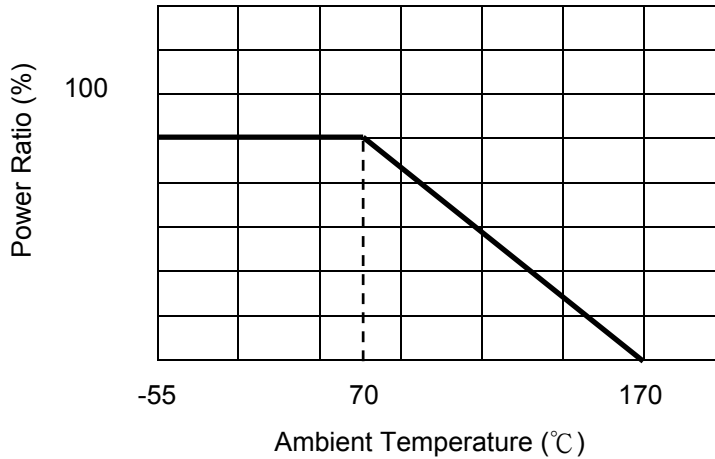

5.2 Rated Voltage

The rated voltage is calculated by the following fomula:

$$V = \sqrt{P \cdot R}$$

V:Rated Voltage(V)

P:Rated Power(W)

R:Resistance Value(Ω)

6. Recommended Solder Pad Dimension

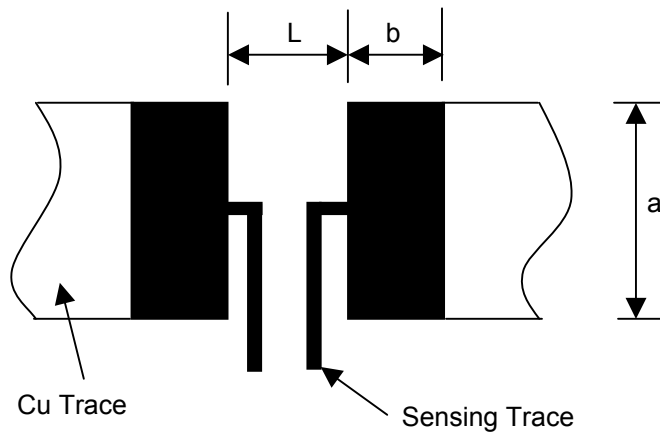

Resistance Range (Ω)	a	b	L
0.010-0.100	4.0	2.1	4.1

Unit:mm

7. Number of Package:

4000 Pieces / package

8. Label:

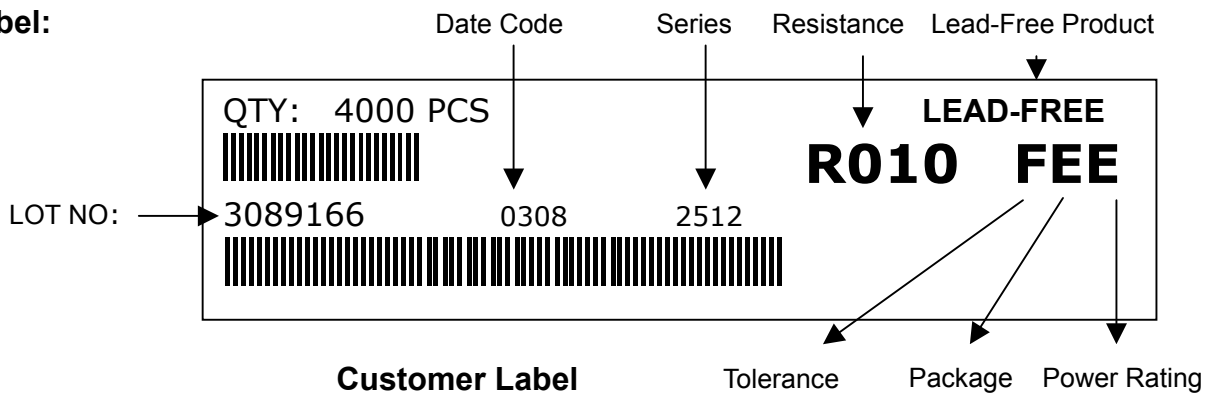

9. Taping

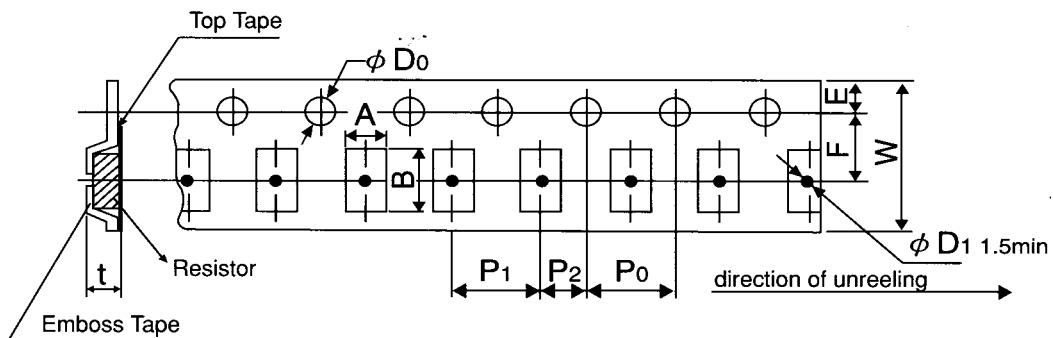

Packing	Type	A	B	W	F	E	P_1	P_2	P_0	D_0	T
Emboss	CRLP	3.6±0.2	6.9±0.2	12±0.2	5.5±0.05	1.75±0.1	4.0±0.1	2.0±0.05	4.0±0.05	$\phi 1.5$ (+0.1/-0)	0.85±0.15

10. Reel Specification

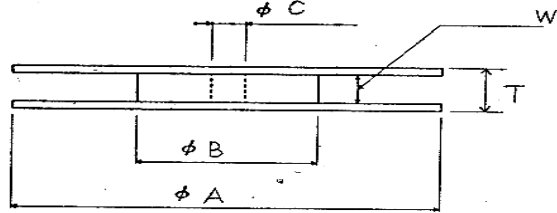
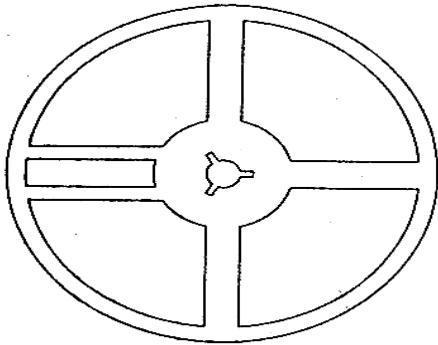

Series	ϕA	ϕB	ϕC	W	T
CRLP	180 ⁺⁰ ₋₃	60 min	13.0±1.0	13.0±1.0	15.4±2.0

11. Peeling Strength of Top Cover Tape

Test Condition: 0.1 to 0.7 N at a peel-off speed of 300 mm / min.

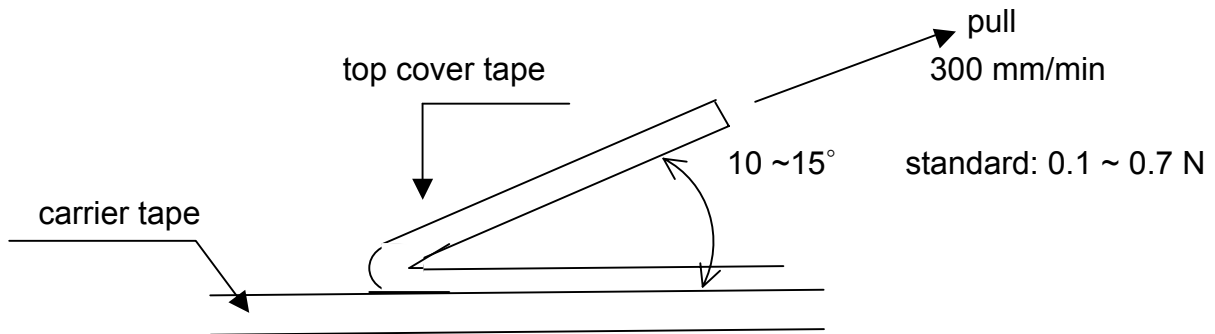

12. Storage Conditions:

Temperature: 5°C~35°C, Humidity: 40%~75%

13. Shelf Life:

2 years from manufacturing date.

14. Recommend IR – Reflow profile : (solder : Sn96.5 / Ag3 / Cu0.5)

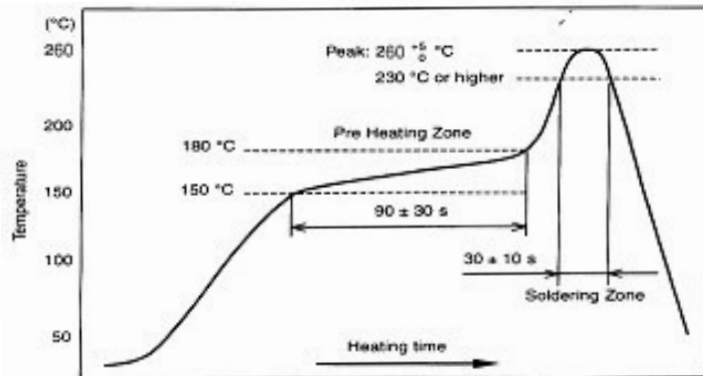

Peak : $260 \begin{matrix} +5 \\ -0 \end{matrix} ^\circ\text{C}$, 5 sec

Pre – heat zone : 150 to 180 °C , 90±30 sec

Soldering zone : 230°C or higher , 30±10 sec